

Design data

Vessel category	Normal pressure	
Description of parameter	Vessel	
Working pressure	psi	ATMP
Design pressure	psi	ATMP
Level testing pressure	psi	ATMP
Medium	Malt	
Material	SUS 304	
Working temperature	°F	15 to 250
Design temperature	°F	15 to 250
Gross volume	BBL	21
Net volume	BBL	15
Heat exchanger area	m2	-----
Glycol Jacket Max Volume	Gallon	-----
Insulation material	Rock wool	
Insulation thickness	mm	100
Total Tank Weight Empty	lbs	2230
Total Tank Weight Full	lbs	6120

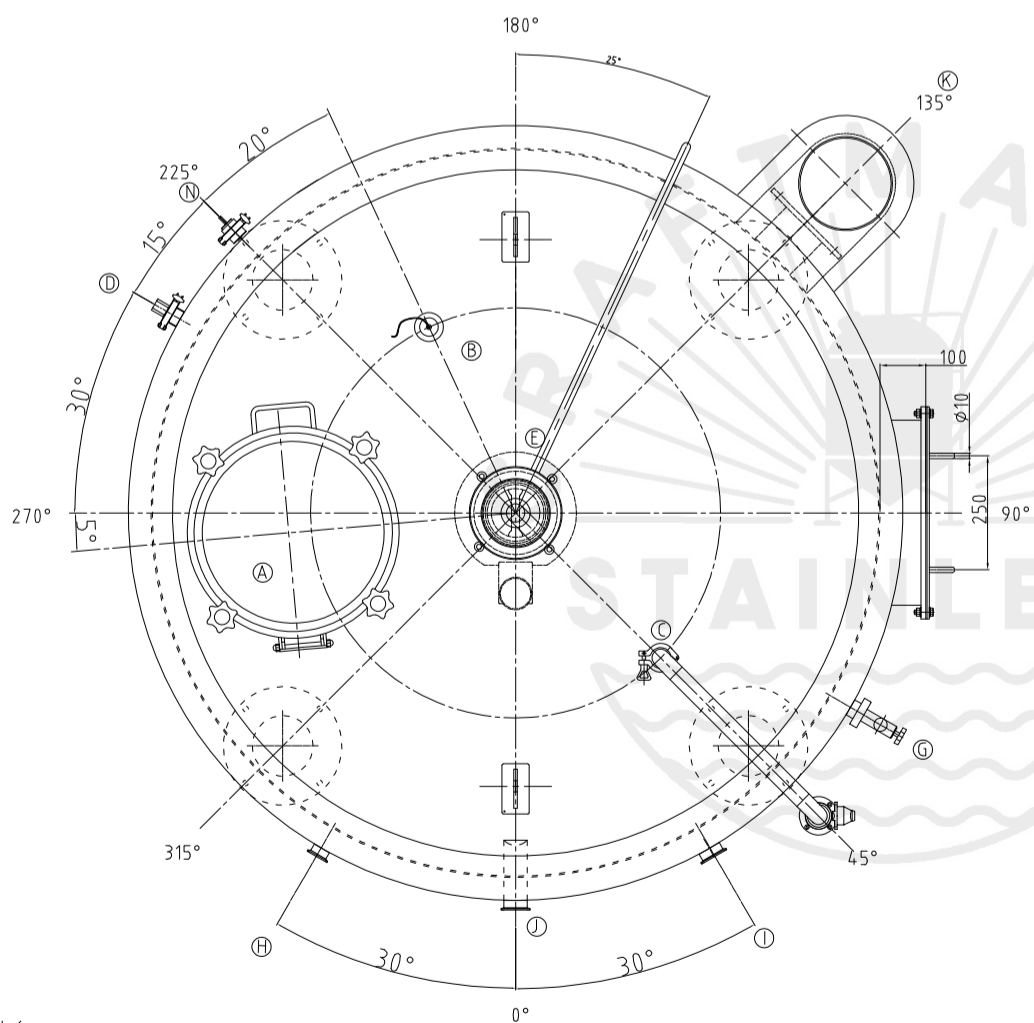

CONNECTIONS				
MARK	DN	DESCRIPTION	CONNECT SIZE	REMARKS
A	φ15.7"	Manway	φ15.7"	ISO
B	DN80	Light	DN80	ISO
C	1.5"	CIP APM FERRULE	1.5"	ISO
D	1.5"	TEMPERATURE CONN	1.5"	NPT
E	8"	EXHAUST CAP	8"	ISO
G	1.5"	LEVEL GAGE	1.5"	ISO
H	1.5"	INLET	1.5"	ISO
I	2"	OUTLET	2"	ISO
J	2"	OUTLET	2"	ISO
K	φ5.2"	Burner flange	φ5.2"	ISO
N	1.5"	Anti Dry Burning Sensor	1.5"	ISO

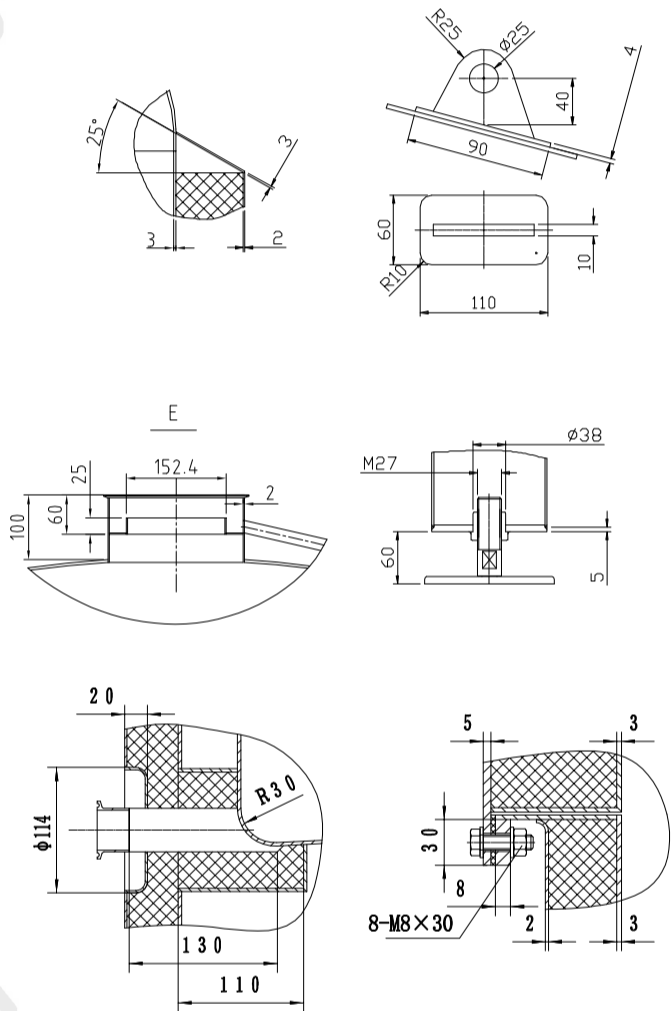
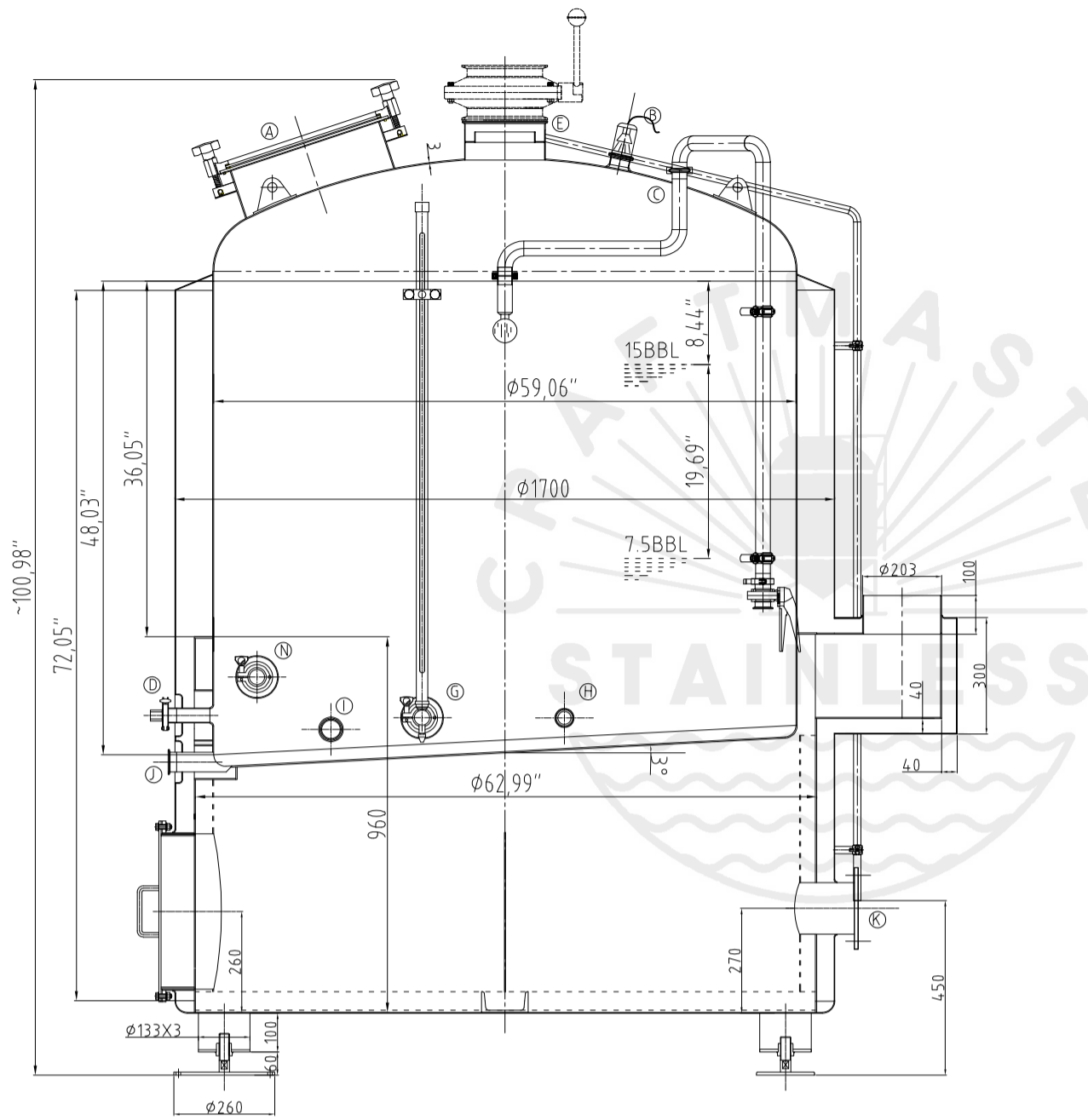
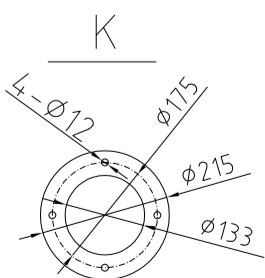

11/16/2022

15BBL KETTLE
[DIRECT FIRE]