

Design data

Vessel category	Normal pressure	
Description of parameter	Vessel	Jacket
Working pressure psi	ATMP	45
Design pressure psi	ATMP	45
Level testing pressure psi	ATMP	60
Medium	Malt	Glycol
Material	SUS 304	SUS 304
Working temperature °F	15 to 250	
Design temperature °F	15 to 250	
Gross volume BBL	39.5	
Net volume BBL	30	
Heat exchanger area m2	7.5	
Glycol Jacket Max Volume Gallon	10	
Insulation material	Chloride Free Polyurethane	
Insulation thickness mm	80	
Total Tank Weight Empty lbs	1720	
Total Tank Weight Full lbs	9475	

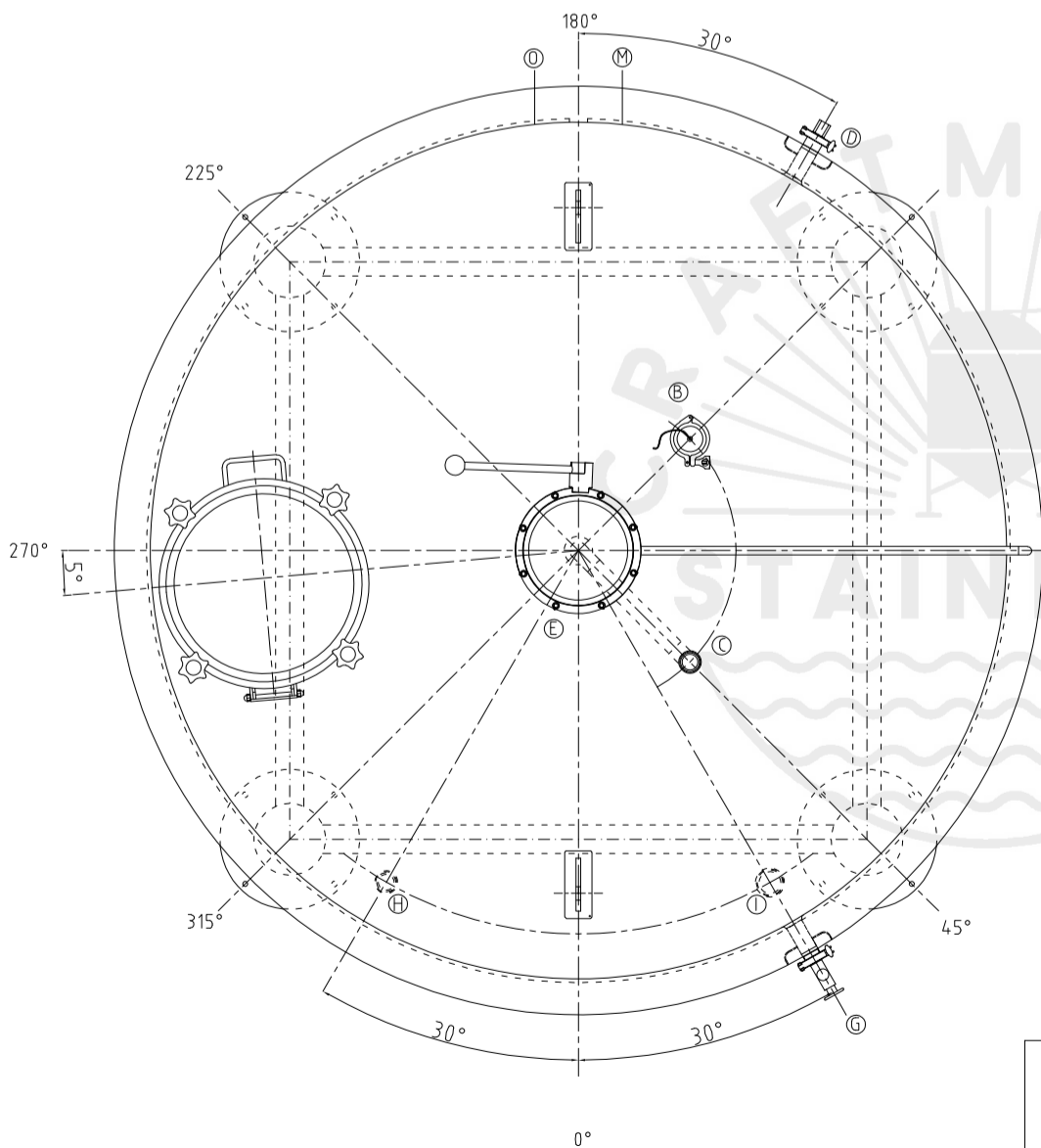
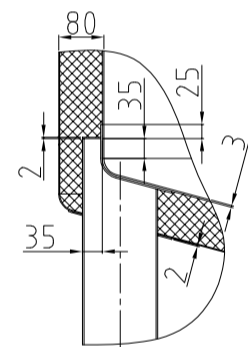
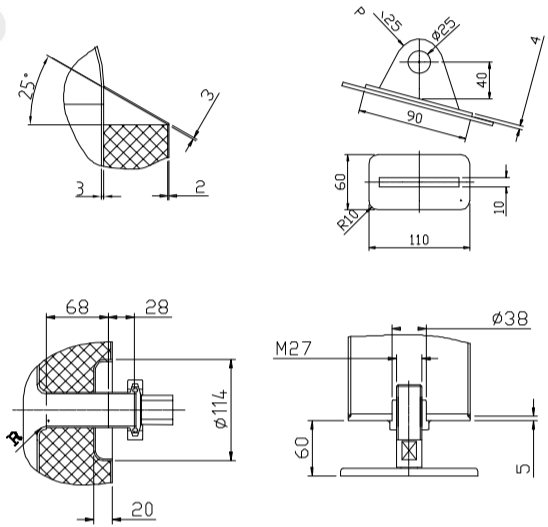
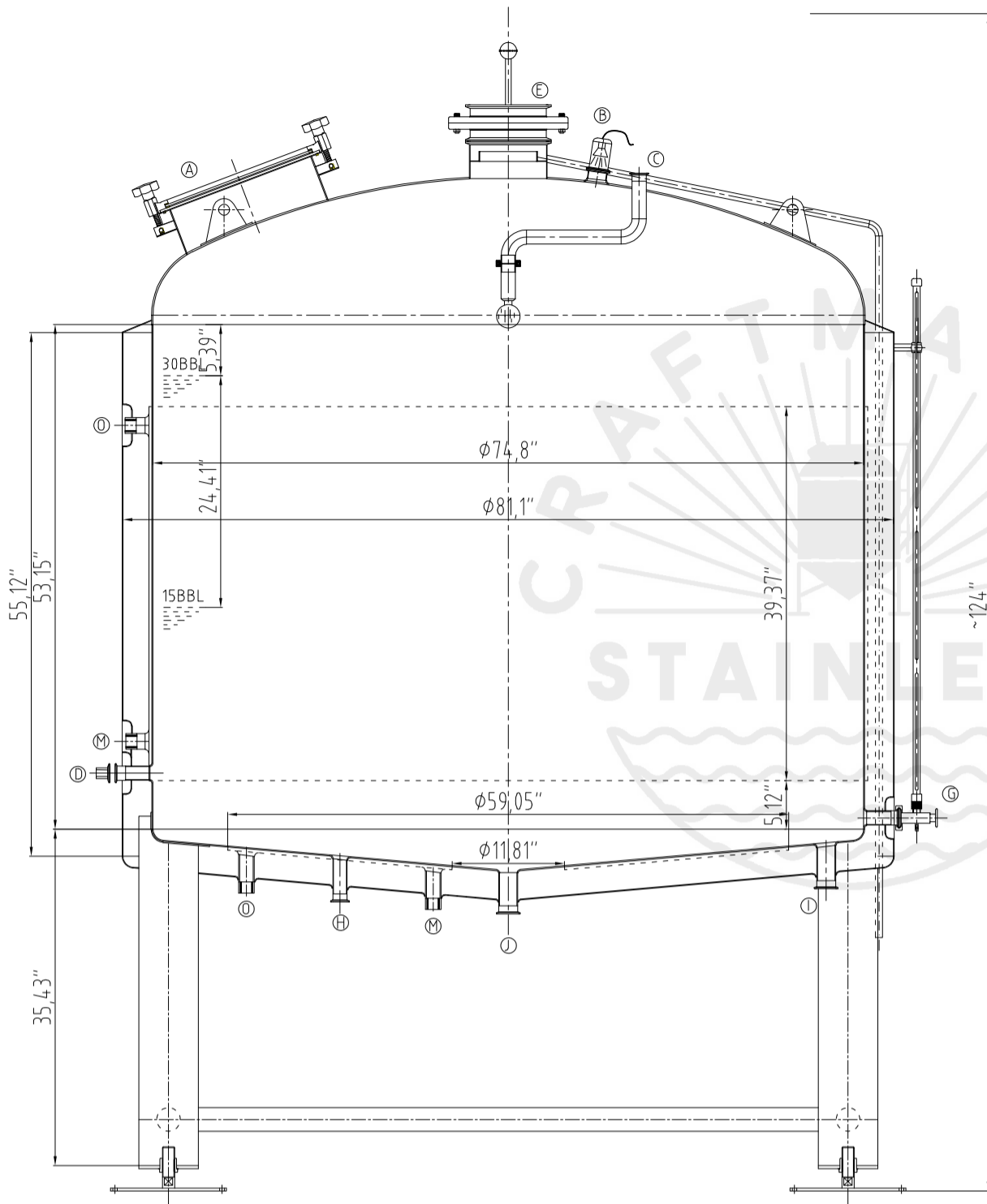

CONNECTIONS

MARK	DN	DESCRIPTION	CONNECT SIZE	REMARKS
A	φ15.7"	Manway	φ15.7"	ISO
B	2"	Light	2"	ISO
C	1.5"	CIP APM FERRULE	1.5"	ISO
D	1.5"	TEMPERATURE CONN	1.5"	NPT
E	8"	EXHAUST CAP	8"	ISO
G	1.5"	LEVEL GAGE	1.5"	ISO
H	1.5"	INLET	1.5"	ISO
I	1.5"	OUTLET	1.5"	ISO
J	2"	OUTLET	2"	ISO
M	3/4"	Steam Inlet	3/4"	NPT
O	3/4"	Steam Outlet	3/4"	NPT



11/12/2022

30BBL KETTLE
[STEAM]