

Design data	
Vessel category	Normal pressure
Description of parameter	Vessel
Working pressure	psi ATMP
Design pressure	psi ATMP
Level testing pressure	psi ATMP
Medium	Malt
Material	SUS 304
Working temperature	°F 15 to 250
Design temperature	°F 15 to 250
Gross volume	BBL 7
Net volume	BBL 5
Heat exchanger area	m2 -----
Glycol Jacket Max Volume	Gallon -----
Insulation material	Rock wool
Insulation thickness	mm 100
Total Tank Weight Empty	lbs 820
Total Tank Weight Full	lbs 2110

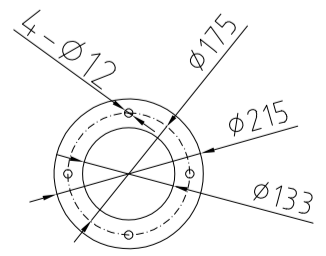

CONNECTIONS				
MARK	DN	DESCRIPTION	CONNECT SIZE	REMARKS
A	ø14"	Manway	ø14"	ISO
B	2"	Light	2"	ISO
C	1.5"	CIP APM FERRULE	1.5"	ISO
D	1.5"	TEMPERATURE CONN	1.5"	NPT
E	8"	EXHAUST CAP	8"	ISO
G	1.5"	LEVEL GAGE	1.5"	ISO
H	1.5"	INLET	1.5"	ISO
I	1.5"	OUTLET	1.5"	ISO
J	1.5"	OUTLET	1.5"	ISO
K	ø5.2"	Burner flange	ø5.2"	ISO
N	1.5"	Anti Dry Burning Sensor	1.5"	ISO

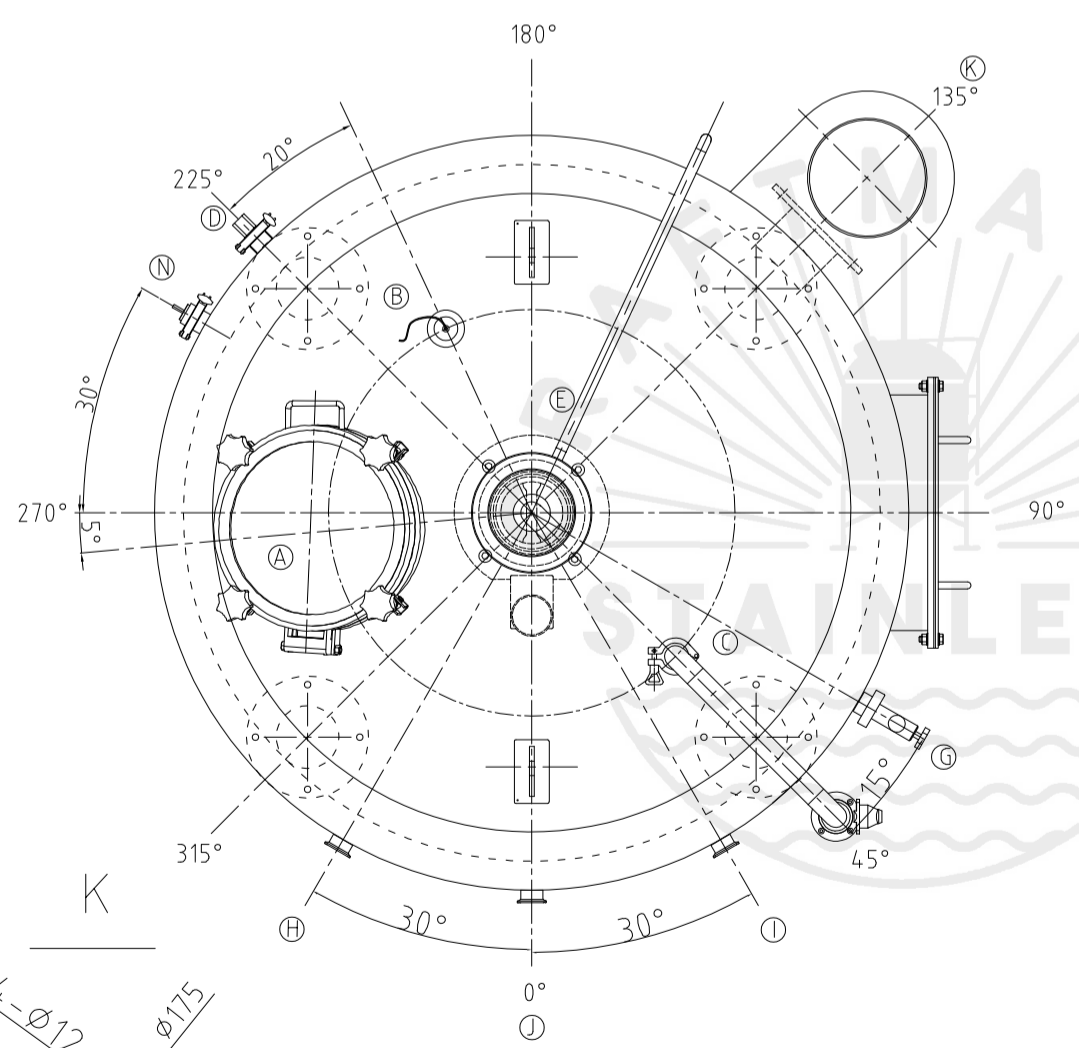
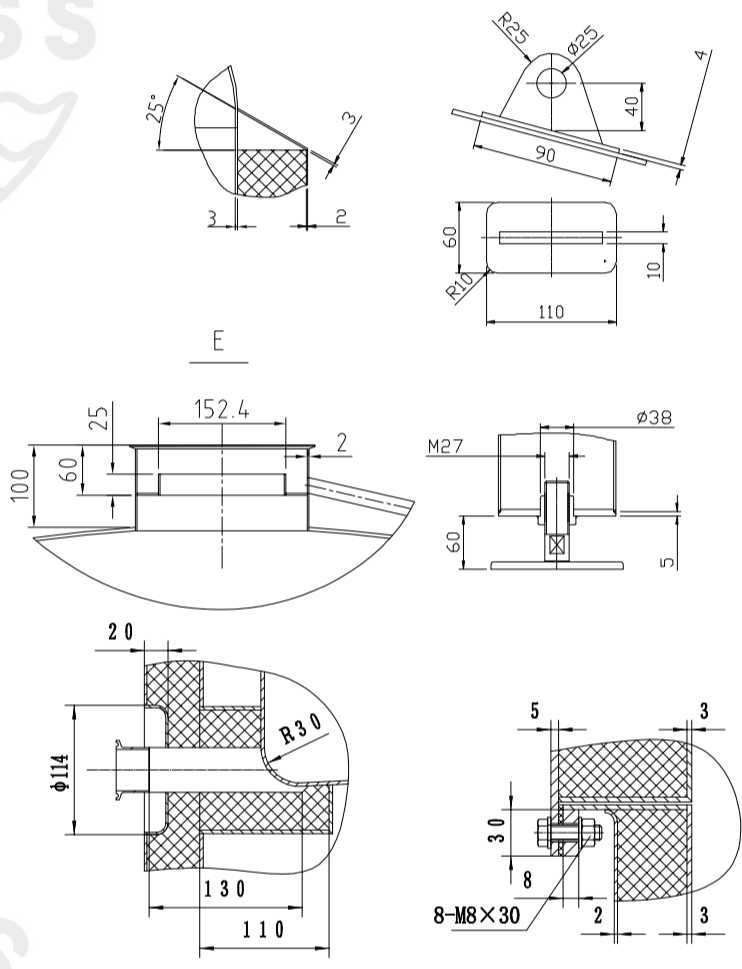

11/16/2022  
5BBL KETTLE  
[DIRECT FIRE]